

#14011 Compound Mitre Jig Instructions



The compound mitre jig eliminates the need for a compound setting on your mitre saw. The principle of the jig is to support crown moulding for mitre cutting in a position the same as it will be installed. This simple principle removes the confusion of cutting crown moulding.

Marking Your Moulding for Cutting

The Compound Mitre Jig is convenient for cutting because the moulding is held in an upside down position. This brings the bottom edge of the moulding to top of the saw fence... right where the saw begins the cut. For this reason, mark your moulding lengths on the edge where it will contact the vertical side of the project. ie cabinet side, wall of the room, etc. This mark will then be closest to the blade when in the jig.

Jig Setup

1. Place a piece of the moulding in the jig with the moulded surface and bottom edge of the moulding (as it will be installed) facing you and against the vertical wall of the jig. Find the natural position of the moulding by slipping the moulding bottom edge higher or lower on the vertical jig wall until the contacting surfaces sit firmly against the wall and base.
2. With the locking knobs released, slide the retainer against the edge of the moulding and lock in place by tightening the knobs firmly.
3. Having already decided which cut you will make and having already set the cut angle of the saw per your saw operators manual, position the jig on the table of the saw appropriate for the cut. Refer to the drawings below.
4. Proceed by cutting the moulding to the mark.

To Cut 90° Inside Corner

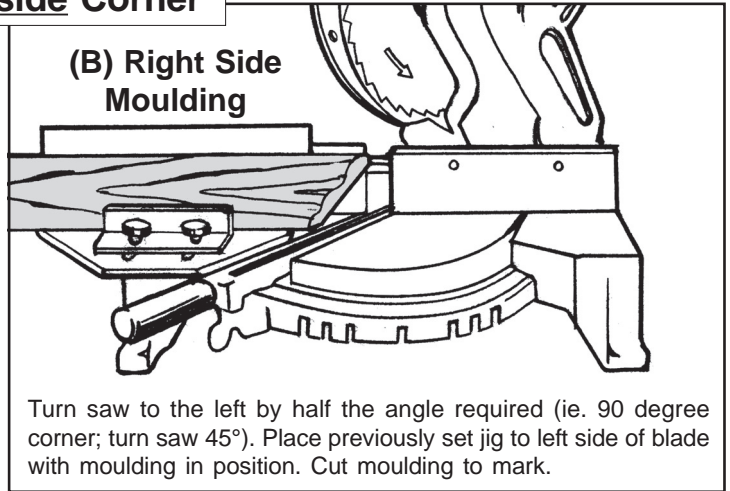
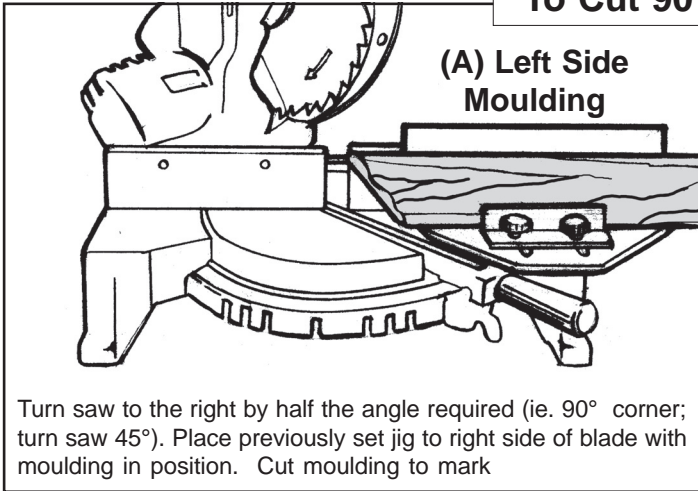

To Cut 90° Outside Corner

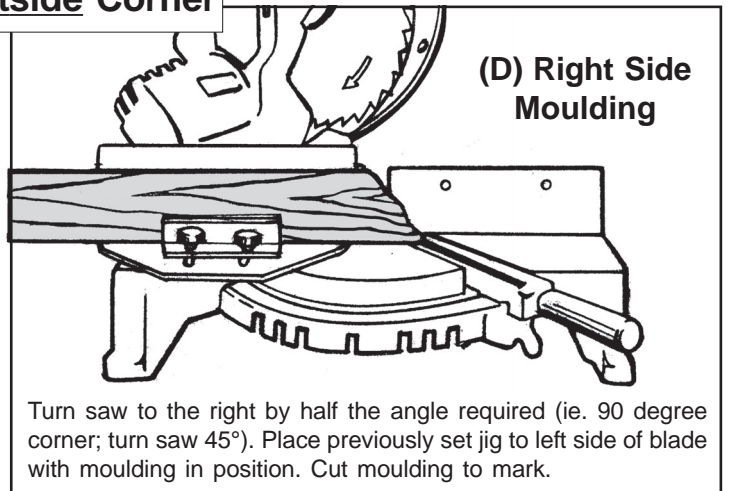
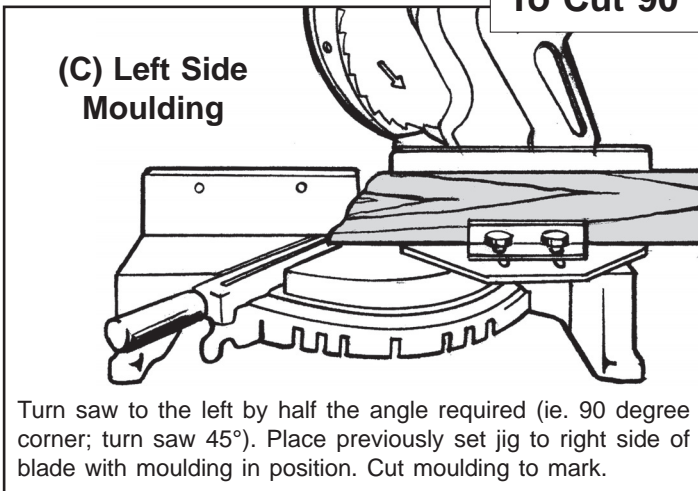

⚠WARNING

Read and familiarize yourself with the owners manual of your mitre saw. Always follow the power tool manufacturer's recommendations. Always wear appropriate safety equipment including, but not limited to, vision and hearing protection. Always maintain a clean work area. Always use extreme caution and always keep to either side of the cutting blade.

⚠WARNING

Never place the mitre jig in the path of the cutting blade. Never operate the saw in a cross-handed position. Always hold the jig and moulding firmly on the table and against fence of the saw.

Visit our website
www.BlackJackCompany.com
 Imported / Importé par Workshop Supply Inc. Embro ON Canada N0J 1J0
 Copyright© 2005 Workshop Supply Inc.